

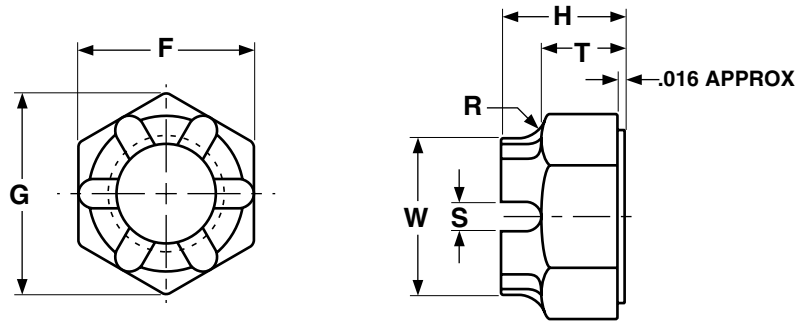

Nuts

Castle Nuts



Nominal Size or Basic Major Diameter of Thread	F			G		H			T			S		R	W	Runout of Bearing Surface FIR	
	Width Across Flats			Width Across Corners		Thickness			Unslotted Thickness and Height of Flat			Width of Slot		Radius of Fillet	Dia. of Cylindrical		
	Basic	Max	Min	Max	Min	Basic	Max	Min	Nom	Max	Min	Max	Min	+010	Min		Max
5/8	0.6250	15/16	0.938	0.922	1.083	1.051	23/32	0.731	0.706	1/2	0.51	0.49	0.24	0.18	0.156	0.797	0.021
3/4	0.7500	1-1/8	1.125	1.088	1.299	1.240	13/16	0.827	0.798	9/16	0.57	0.55	0.24	0.18	0.188	0.941	0.023
7/8	0.8750	1-5/16	1.312	1.269	1.516	1.447	29/32	0.922	0.890	21/32	0.67	0.64	0.24	0.18	0.188	1.097	0.025
1	1.0000	1-1/2	1.500	1.450	1.732	1.653	1	1.018	0.982	23/32	0.73	0.70	0.30	0.24	0.188	1.254	0.027

ANSI B18.2.2 1970

The value-added source for quality bolts, screws, nuts, washers and other industrial fasteners.

3211 West 9th Street, Trainer, PA 19061-5242 TOLL FREE: 1-800-662-7459 LOCAL: 610-485-5700 FAX: 610-485-5877

E-MAIL: sales@coburnmyers.com